

5 APPROVAL

The non moving parts of **AIRDOME®** units are guaranteed for ten years (when installed and used in accordance with Axter Ltd specifications). **AIRDOME®** conforms to regulatory standard NFP 37-418. Waterproofing details conform to BS Code of practice BS 8217 : 2005

AIRDOME®, with its structured polycarbonate glazing, is approved by the CSTB Avis Technique No. 2/03-1027.

Resistance to upward static load: 1000 pa (1000 N/m²)
Resistance to downward static load: 1500pa (1500 N/m²)

Fire rating data and 1200 joules test data can be found on our website: www.skydome-axt.com under the heading "Espace Partenaires" (Partner information).

6 OPTIONS

- Steel kerb pre-painted in CLASSIC WHITE
- Steel kerb painted after manufacture in one of the main RAL colours
- Anti fall/intruder grill tested to 1200 joules
- Painted anti-fall/intruder grill tested to 1200 joules
- Domes 1200 joules
- Domes, pyramid domes
- Quadruple-walled PCA 10, PCA 16, etc.
- Alternative insulation for roofs with PVC waterproofing

Options for Adapter Plates:

- Insulation
- Length of foot can be from 50 to 180mm (and more on request)

8 GEOMETRIC DIMENSIONS

DIMENSIONS OF ROOF OPENING A X B* (CM)	LIGHT TRANSMISSION SURFACE (M2)	OVERALL DIMENSION C X D* (CM)	AIRDOME®			
			H (cm)		H1 (cm)	
			With domes	With structured polycarbonate	With domes	With structured polycarbonate
50 x 50	0.25	68 x 68	49	39	35	25
85 x 85	0.72	103 x 103	56	39	42	25
100 x 100	1.00	118 x 118	58	39	44	25
120 x 120	1.44	138 x 138	60	39	46	25
140 x 140	1.96	158 x 158	63	39	49	25
150 x 150	2.25	168 x 168	68	39	54	25
160 x 160	2.56	178 x 178	68	39	54	25
180 x 180	3.24	198 x 198	70	39	58	25
195 x 200	3.90	213 x 218	--	39	--	25
200 x 200	4.00	218 x 218	73	--	59	--
70 x 100	0.70	88 x 118	54	39	41	25
100 x 150	1.50	118 x 168	58	39	44	25
100 x 200	2.00	118 x 218	58	39	44	25
140 x 200	2.80	158 x 218	66	39	52	25

*B & D are the hinged and longest sides of the unit.

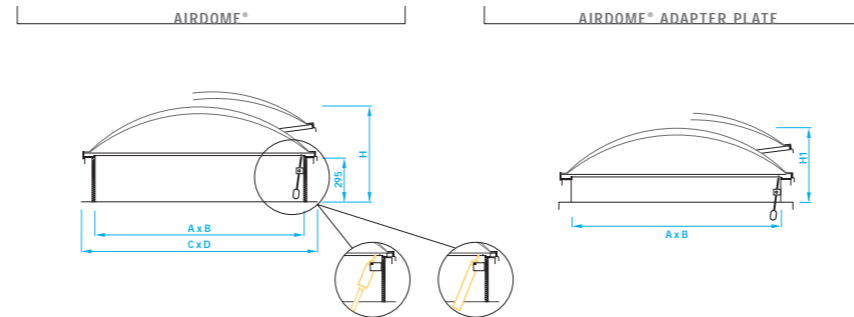

7 INSTALLATION

Installation should be carried out in accordance with current regulations. Decks should be sound and resistant and should conform to the requirements of current decking standards and of the installation guide. Maximum roof slope: 25°, i.e. 45%.

If the slope of the roof is less than 25°, the hinged side of the unit must be parallel to the slope. If the slope of the roof is less than 3° there is no particular requirement.

Fixing: in accordance with the current DTU standards series 43, in the case of a standard kerb, on metal, timber or concrete deck. If an adapter plate is used, this is adapted for installation on to an existing kerb or concrete surround (see installation guide).

Waterproofing seal:

- The bitumen-faced insulation on the standard kerb guarantees a seal with waterproofing detailing material.
- Zinc or lead flashing should be installed in situ to create a seal with roof tiles or slates.
- A co-laminated metal sheet is used for PVC membranes.

Maintenance: Glazing must be washed with soapy water. Corrosive products or solvents must not be used.

ROOF VENTILATION / ROOFLIGHTS / NATURAL DAYLIGHTING

AIRDOME®

Ref. AIRDOME® 2005 - The manufacturer reserves the right to alter the design of its products. Characteristics provided in this publication derive from data obtained under controlled test conditions. Axter makes no warranties, express or implied, as to the properties and performance under any variations from such conditions in actual construction. BEFORE COMMUNICATION.



AXTER LTD
Cliff Road Ipswich Suffolk IP3 0AY - UK
Tel : 01473 217154 - Fax: 01473 232118
<http://www.axter.co.uk> - Email : sales@axterltd.co.uk





AIRDOME* is a rooflight unit designed to provide static ventilation and to allow natural daylight into a building. It is used on flat and low slope roofs with waterproofing and on tiled or slate pitched roofs on all types of buildings:

- Public access buildings
- Industrial buildings
- Commercial buildings, offices
- Residential buildings

New work: Ideal for new roofs. The standard kerb is 310 mm high with a 90 mm wide base plate

For refurbishment and renovation works using an existing or new builder's kerb:

- The adapter plate is 170 mm high with a foot of 83 mm (other sizes are available upon request).

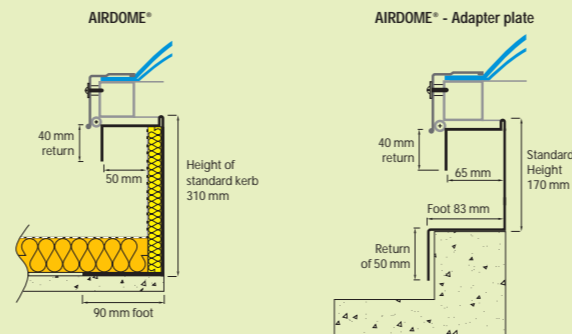

3 FUNCTION

Manual opening and closing of the **AIRDOME***:

The continuous worm screw is activated by the movement of a winding handle, available in different lengths according to the height of the ceiling.

Ceiling from 2m to 2.5m	=	Winding handle 1.5m long
Ceiling from 2.5m to 3m	=	Winding handle 2m long
Ceiling from 3m to 3.5m	=	Winding handle 2.5m long
Ceiling from 3.5m to 4m	=	Winding handle 3m long
Ceiling from 4m to 4.5m	=	Winding handle 3.5m long

Electric opening and closing of the **AIRDOME***:

The opening and closing of the unit is operated by an electric cylinder connected to the 220/240 volt supply. This cylinder is activated by a 3 position electric interrupter, available as an option.

Pneumatic opening and closing of the **AIRDOME***:

A double action pneumatic cylinder (ref. XAJ100), powered by the existing pneumatic network, operates the opening and closing mechanism.

Rain or rain and wind detectors are available to order.

ROOFLIGHTS WITH NATURAL VENTILATION

AIRDOME®



1 ADVANTAGES

AIRDOME*:

In the open position, an **AIRDOME*** unit allows air passage to a height of 250mm.

AIRDOME* can be opened by the following methods:

- Manual opening: by 250mm continuous worm screw, operated by a winding handle
- Electric – by a 300mm electric cylinder linked to the standard electricity circuit (220/240V)
- Pneumatic – by a 300mm pneumatic cylinder linked to the pneumatic network of the installation

High resistance to corrosion: the galvanised steel kerb is assembled by crimping

This assembly technique, used in car manufacturing, avoids the use of welding which requires subsequent reconditioning to achieve a level of protection equivalent to galvanisation. **AIRDOME*** units are therefore highly resistant to the effects of weathering and corrosion, even if scratched.

Colour Finish: **AIRDOME*** rooflight units are available in galvanised steel or, upon request, in steel and pre-coated in CLASSIC WHITE colour. They can also be painted after manufacture in one of the main RAL colours (thickness of pre-coating: 25µ, thickness of final coating: over 25µ).

AIRDOME* is an architectural feature of the roof.



2 COMPOSITION

AIRDOME* units are made up of the following components:

- **Kerb:** this is the main component of the unit. The opening part of the unit and the opening mechanism, cylinder motors or continuous worm screw, are fitted to the kerb. The standard kerb in galvanised steel is assembled by crimping. The straight sided kerb is covered on the outside by bitumen-surfaced thermal insulation designed to accept torch-on waterproofing membranes. Adapter Plates can be insulated upon request. Alternative insulation to meet Class 'O' or to enable the units to be installed with single-ply roof membranes is available upon request.
- **A tubular opening frame in galvanised steel:** this is hinged to the kerb and the amount of opening is determined by the length of the cylinder motor or of the continuous worm screw.
- **Glazing:** as standard either 10 mm reinforced, structured opalescent polycarbonate sheet (PCA) (tested to 1200 joules) or polycarbonate double domes. The following options are also available: 10 and 16 mm polycarbonate, triple- or quadruple-walled structured polycarbonate sheet for better thermal resistance or an aluminium cover. Single dome or pyramid dome available on request. All PCA glazing has anti UV treatment. To choose the type of glazing required, see the table entitled "Glazing - Performance". The positioning of the glazing and the design of our units reduces the build-up of condensation as air circulates between the frame and the kerb.
- **Aluminium beading frame:** fixed by stainless steel screws and nylon washers. This holds the glazing in place and protects edges from lateral impact. It also improves the aesthetic appeal of the **AIRDOME***.

4 GLAZING - PERFORMANCE

TYPE OF GLAZING	THERMAL TRANSMISSION U W/M2 °C	LIGHT TRANSMISSION (%)	FIRE CLASSIFICATION (BUILDING REGULATIONS ENGLAND AND WALES 2002)	ACOUSTIC PERFORMANCE (DB(A))
Double polycarbonate	3.1	81	Tp(e)	
10mm structured polycarbonate - clear	3.1	85	Tp(e)	17
10mm structured polycarbonate - opal	3.1	62	Tp(e)	17
10mm structured polycarbonate - Venetian	3.1	33	Tp(e)	17
10mm structured polycarbonate - Comfort	3.1	55	Tp(e)	17
10mm structured polycarbonate -				
4-walled - opal	2.5	55	Tp(e)	17
16mm structured polycarbonate - clear	2.3	79	Tp(e)	21
16mm structured polycarbonate - opal	2.3	57	Tp(e)	21
16mm structured polycarbonate -				
K clear	2	72	Tp(e)	21
16mm structured polycarbonate -				
K opal	2	57	Tp(e)	21
16mm structured polycarbonate -				
K Comfort	2	50	Tp(e)	21
Aluminium cover 10	3.1	0	'0'	17
Aluminium cover 20	0.98	0	'0'	
Aluminium cover 60	0.6	0	'0'	24